

The GO Station Precinct Project Pre-construction Open House

Contract No. 2023-T-249

This Project is in partnership with the Niagara Region,
City of St. Catharines and the Canadian National Railway

Niagara  Region

 Growing
Better
Together

 St. Catharines

Agenda

- Welcome and Introductions
- 6:05p.m. – Presentation (15 minutes)
- 6:20-6:50p.m. – Questions to the Presentation (30 minutes)
- 6:50-8:00pm – Open House

Tonight's Expectations

Why are we meeting tonight?

To provide the neighbourhood around the train station (referred to as the GO Station Precinct Area) an update on the City and Region-led project that is about to begin construction.

Tonight is an Open House, not a Public Information Centre (PIC)...

- For any of the specific projects
- For a review of previous infrastructure or policy decisions
- Will not examine neighbourhood development(s)
- Not intended to address specific residential property issues
- Will not be addressing any GO Transit services (bus or train)

Tonight's Expectations cont'd

Housekeeping Items:

- Always respect your neighbours and staff
 - Ask questions respectfully
 - One discussion – avoid side conversations
- Washrooms
- Please keep in mind that we are visitors on Ridley's Campus – please stay within Open House area (Williams Hall)

Timeline

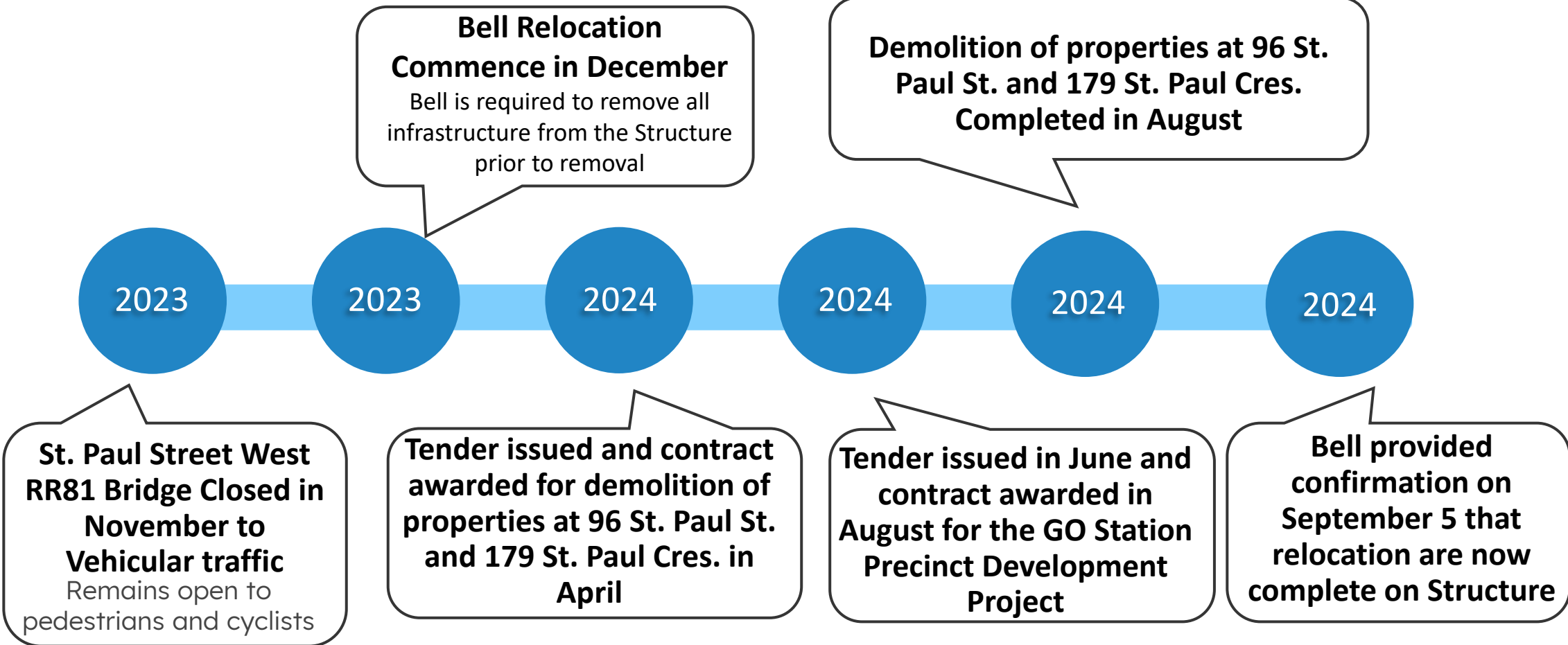

GO Station Precinct Project

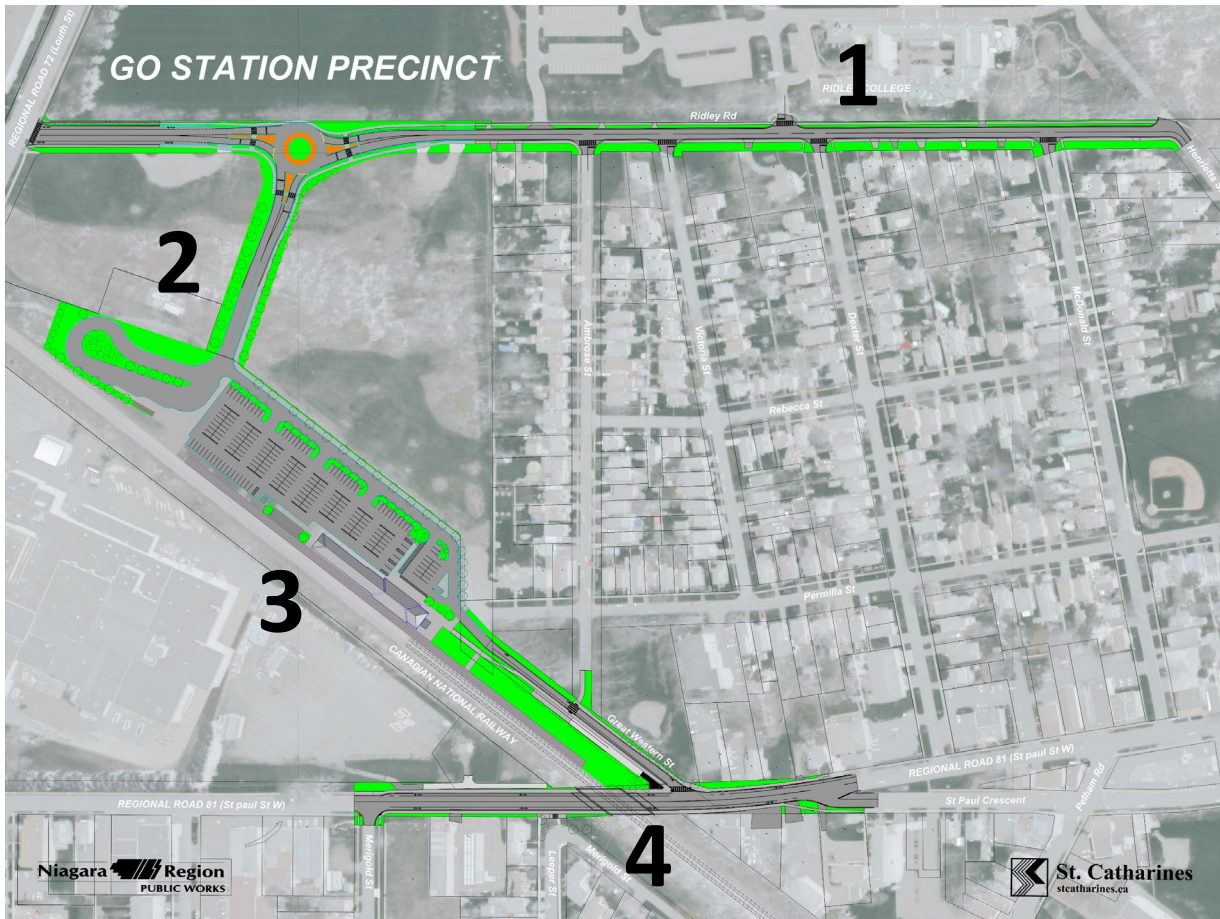

Associated Parts of the Project:

1. Ridley Road Reconstruction (City of St. Catharines)
2. Station access road (Miller Road) from Ridley Road to the St. Catharines GO Station (Niagara Region and City of St. Catharines)
3. GO Station Site Redevelopment (Niagara Region)
4. St. Paul Street West CNR Bridge replacement (Niagara Region, CNR, St. Catharines)

Project Highlights:

- 8,000 tonnes of Asphalt
- 78,000 tonnes of Granular Material
- 3,400 m³ of Concrete
- New Pedestrian Crossover on Ridley Road
- Over 4,805m of Curb
- 175 drawings in the “Issued for Construction” set
- 95 individual tactile surface plates

Construction Schedule

ACTIVITY	TIMING	NOTES
St. Paul Street Bridge Demolition	October 2024 - December 2024	<ul style="list-style-type: none"> - Contractor to submit Demolition plans to CNR for approval prior to demolition. - CNR has approved a 48-hour full closure of the railway to complete demolition.
Access Road Construction	October 2024 - December 2024	- Access Road to Station must be constructed prior to bridge reconstruction to ensure access to station is maintained
St. Paul Street Bridge and Roadway Reconstruction	January 2025 – July 2026 (Bridge to be reopen to at least a single lane of traffic by December of 2025)	- Construction will continue though winter season until completion.
Station Redevelopment	May 2025 – August 2026	-Station redevelopment to be completed in 2 stages to ensure access to station is maintained during construction.
Ridley Road Reconstruction	May 2025 – August 2026	- Full reconstruction including the construction of a Roundabout for Station access.

Pedestrian Detour

What is the pedestrian and cyclist detour route?

Westbound

St. Paul Street West to Pelham Road to Chetwood Street to Merigold Street to St. Paul Street West

Eastbound

St. Paul Street West to Merigold Street to Chetwood Street to Pelham Road to St. Paul Street West

- The pedestrian detour will begin when the bridge is removed and continue until the new bridge is inplace



Pre-construction Notices and Pre-condition Survey

MOVING ROADS FORWARD

Public Works
1815 Sir Isaac Brock Way, PO Box 1042,
Thorold, ON L2V 4T7
Tel: 905-980-6000 Toll-free: 1-800-263-7215
Fax: 905-685-0013
niagararegion.ca

2024-09-23

Pre-Construction Notice to Residents
Contract No. 2023-T-249 - GO Station Precinct Development Project



Please be advised that Niagara Region will be commencing the GO Station Precinct Development Project located on St. Paul Street West, Great Western, Ambrose and Ridley Road in the City of St. Catharines under **Contract No. 2023-T-249**.

This contract will be carried out on behalf of Niagara Region by Rankin Construction Inc. Construction is tentatively scheduled to begin in the coming weeks.

- Construction of the new St. Paul Street Bridge is anticipated to be completed by the end of December 2025, weather permitting.
- Reconstruction of Ridley Road and the redevelopment of the existing station is anticipated to be completed by the end of August 2026, weather permitting.

CONNECTING MORE PEOPLE TO MORE POSSIBILITIES 

OZA Inspections Ltd.

202, 400 Jones Road
Stoney Creek, ON L8E 5P4
Toll Free 1-800-667-8263
Tel: (905) 643-1074
appt@ozainspections.com
www.ozainspections.com

September 16, 2024 **OZA File: 23421**

Dear Resident and/or Property Owner: **DRAFT**

Re: **CONDITION SURVEY**
City of St. Catharines
GO Station Precinct Development Project
Project No. No 2023-T-249
St. Catharines, ON

Construction operations are scheduled to commence in the near future.

We are conducting a survey of property next to the project site to verify existing conditions. This includes your property at no cost to you.

To arrange the survey, call or email as soon as possible:
Toll free 1-800-667-8263 extension 231 or email appt@ozainspections.com Indicate your name, address, telephone number and refer to File: 23421 Please advise if we may inspect your building exterior at any time.

Rankin Construction will be completing work for the above mentioned project. Work will entail bridge demolition, Ridley Road and St. Paul Street West reconstruction. This condition survey is important in the unlikely event that issues arise during the construction. Survey involves an interior and/or exterior inspection and documentation of buildings and structures determined to be in close proximity to the project work area. Photographs are taken as part of the survey. While the preconstruction inspection is voluntary, your permission and cooperation in helping us complete this survey as soon as possible is greatly appreciated.

Should you have any questions regarding the construction or the authenticity of this project, you may contact the office of **Rankin Construction**, at (905)-684-1111.

Yours truly,
OZA Inspections Ltd

Christine K Mrakuzic
Project Coordinator

Pre-construction Notice

**MOVING
ROADS
FORWARD**

Public Works
1815 Sir Isaac Brock Way, PO Box 1042,
Thorold, ON L2V 4T7
Tel: 905-980-6000 Toll-free: 1-800-263-7215
Fax: 905-685-0013
niagararegion.ca

2024-09-23

Pre-Construction Notice to Residents
Contract No. 2023-T-249 - GO Station Precinct Development Project



Please be advised that Niagara Region will be commencing the GO Station Precinct Development Project located on St. Paul Street West, Great Western, Ambrose and Ridley Road in the City of St. Catharines under **Contract No. 2023-T-249**.

This contract will be carried out on behalf of Niagara Region by Rankin Construction Inc. Construction is tentatively scheduled to begin in the coming weeks.

- Construction of the new St. Paul Street Bridge is anticipated to be completed by the end of December 2025, weather permitting.
- Reconstruction of Ridley Road and the redevelopment of the existing station is anticipated to be completed by the end of August 2026, weather permitting.

CONNECTING MORE PEOPLE TO MORE POSSIBILITIES

Niagara Region

- What is a Pre-construction Notice?
- Why are Pre-construction Notices necessary?

Pre-condition Survey

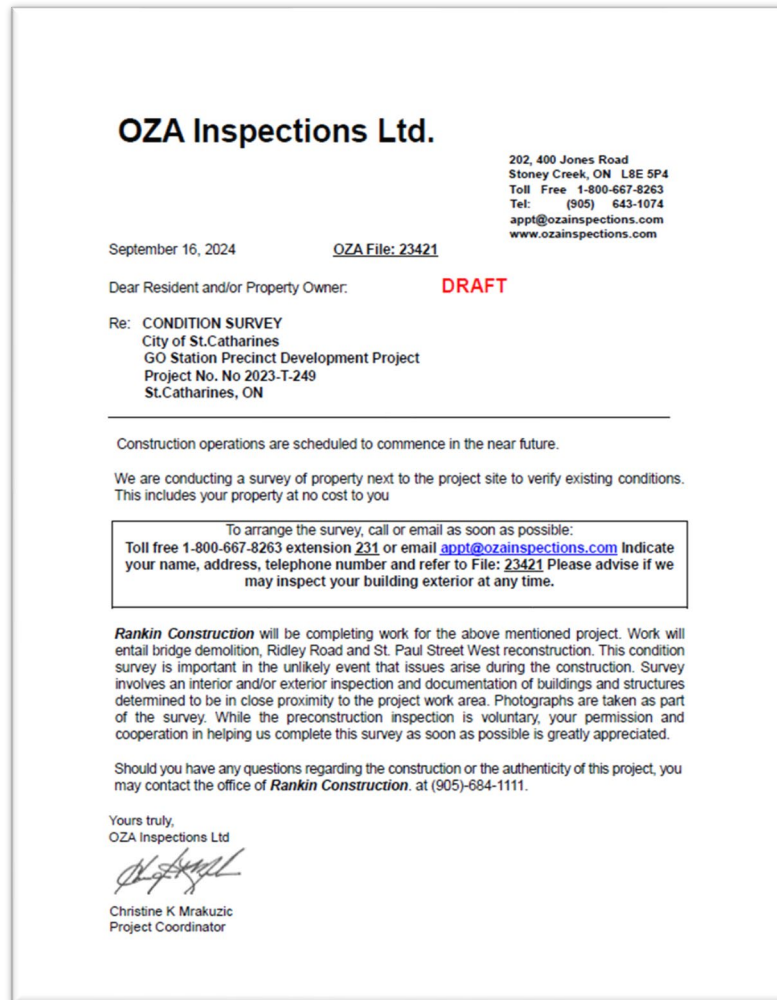

- What is a Pre-condition Survey?
- How are Pre-condition Surveys conducted?
- Why is a Pre-condition survey important?
- Will my property be affected by construction?

Heritage Features

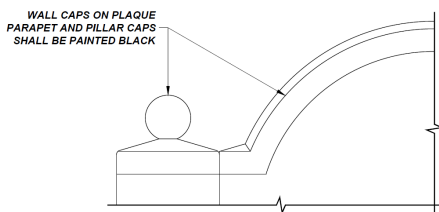
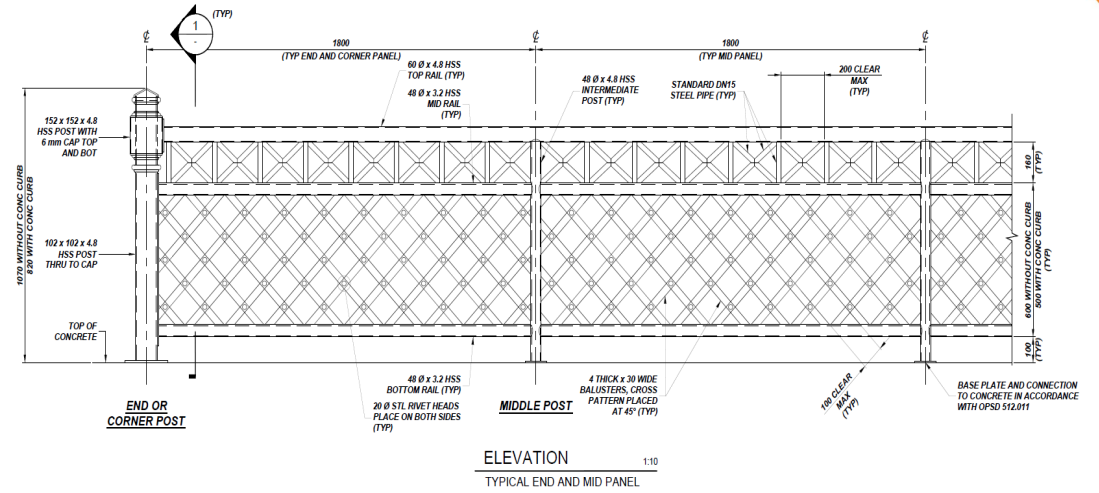
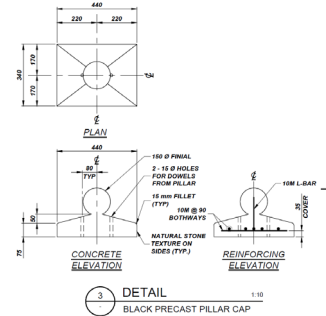
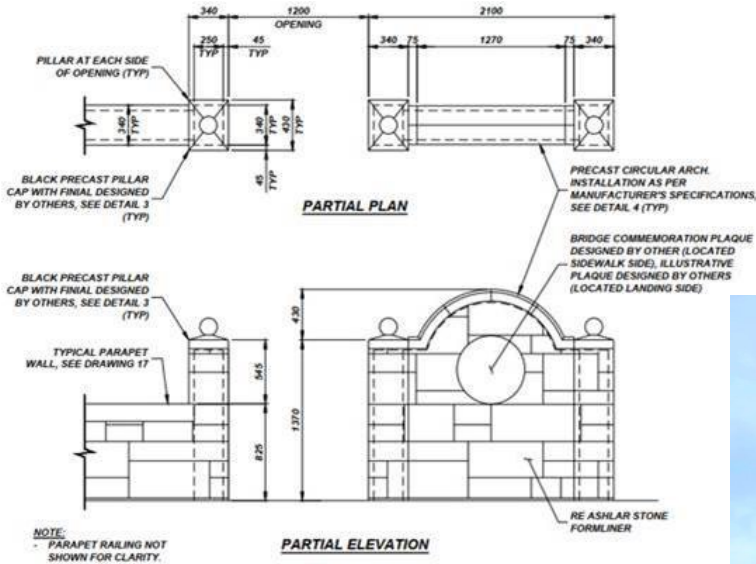

Gateway Features

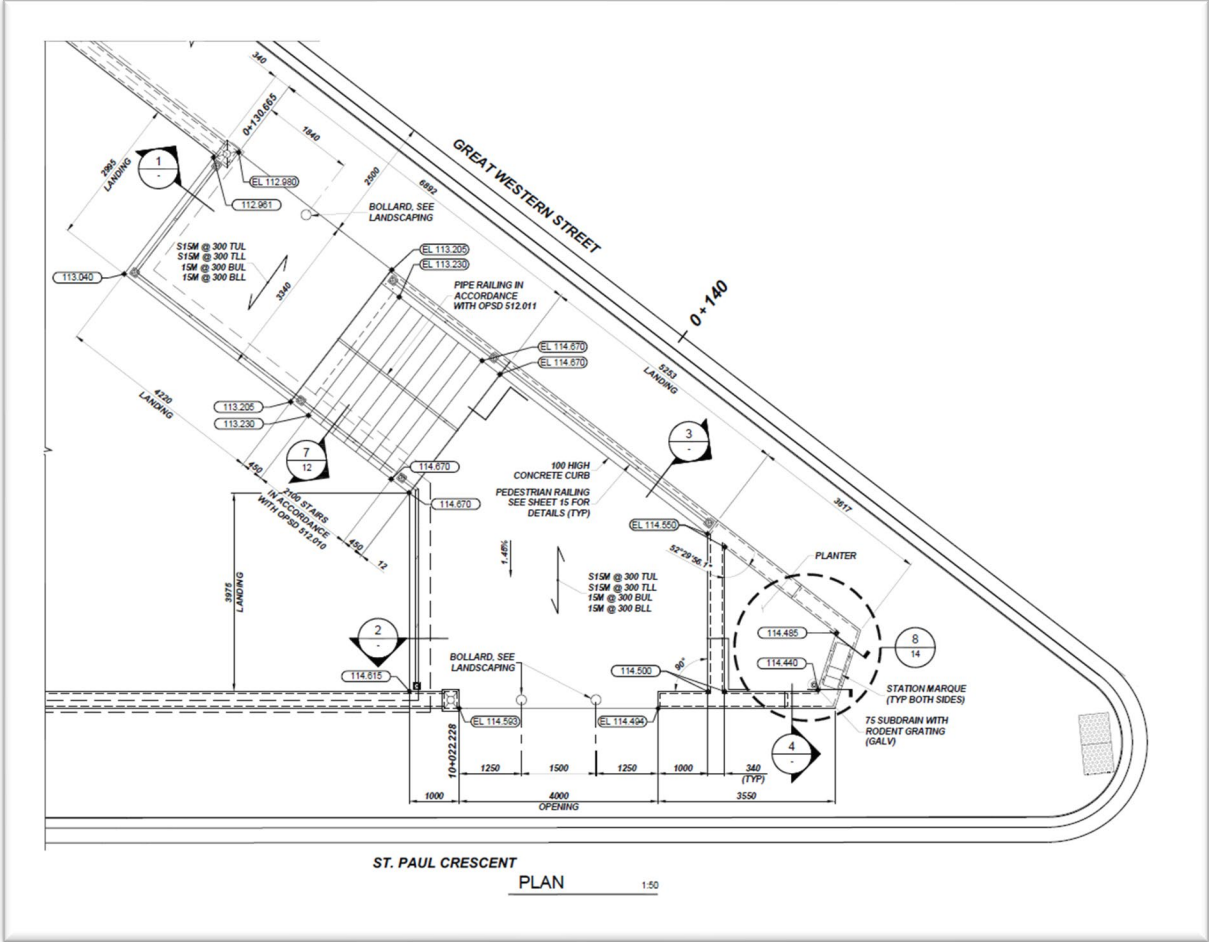
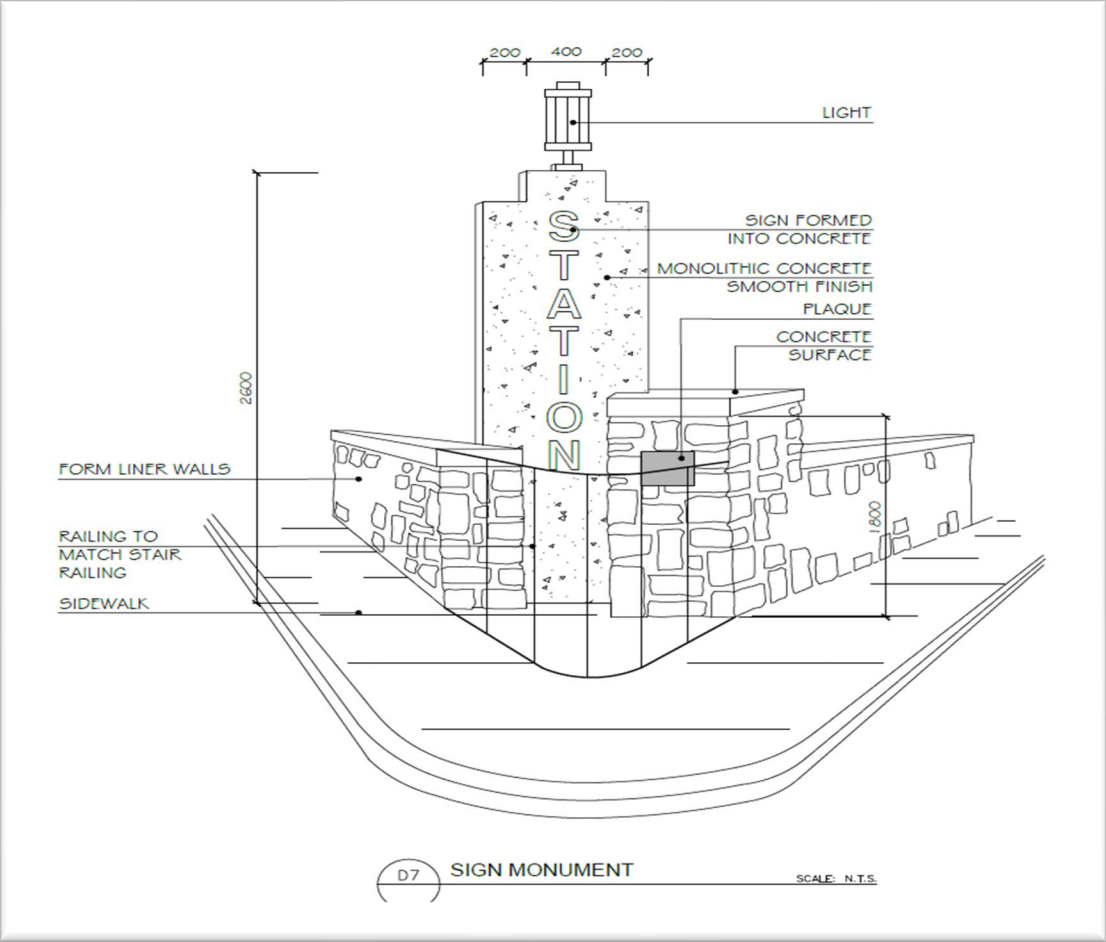

St. Catharines Station Redevelopment

- Originally constructed in 1917
- Undergoing several stages of restoration
- Redevelopment of the Station is being completed outside of the Go Station Precinct Contract

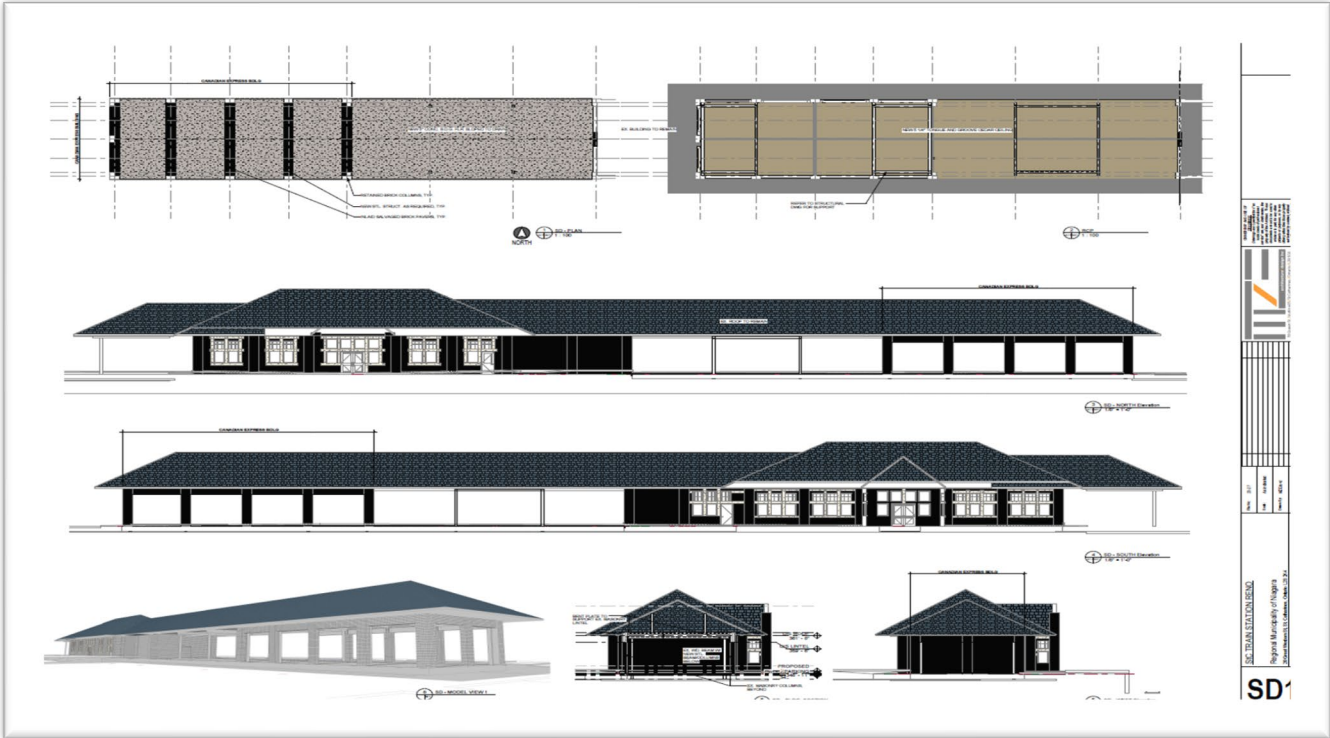

Questions

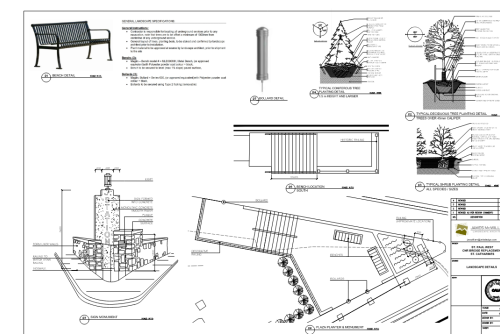
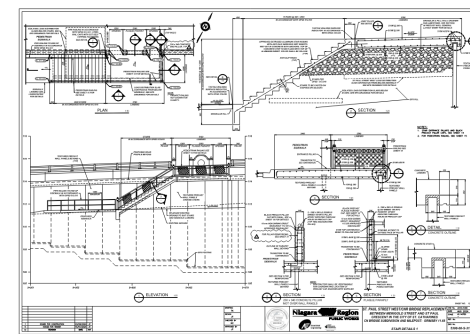
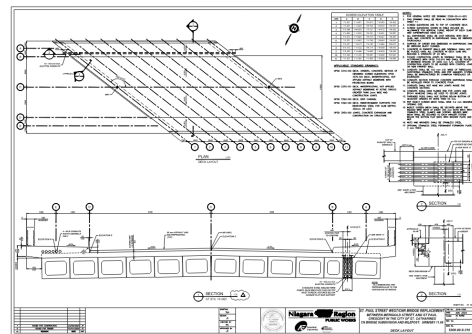
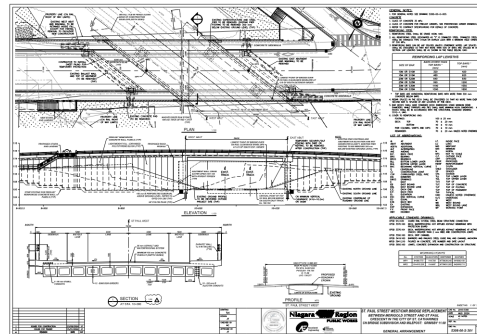
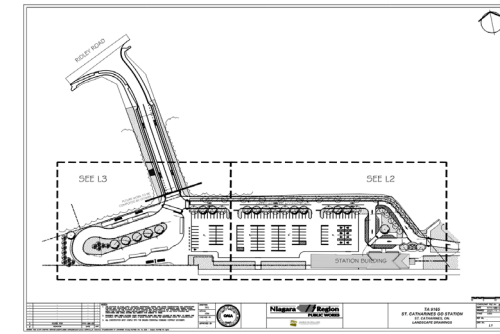
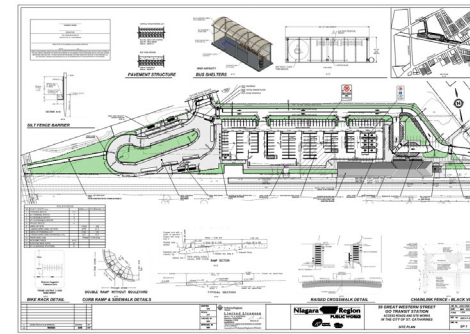
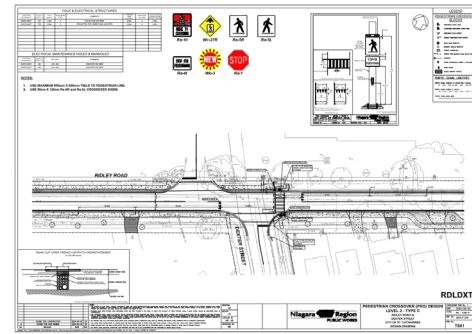
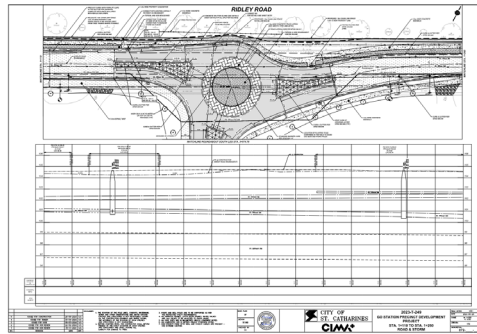

- Keep questions to information/projects in the presentation
- Staff are available at the information boards to speak with you individually and answer any site-specific questions
- Detailed plans are available to be viewed in the lobby after the presentation

Thank You Future Updates

- Updates will be provided on the Niagara Region webpage and social media feed
- <https://www.niagararegion.ca/projects/stpaul-go-precinct-development/default.aspx>
- stcatharines.ca/en/roads-parking-and-traffic/construction-map.aspx

St. Paul Street West (Regional Road 81) - GO Station Precinct Development Project
[All Niagara Region projects](#)

About the project
Niagara Region completed a Municipal Class Environmental Assessment for the replacement of the St. Paul Street West CN Rail Bridge in St. Catharines.

Originally constructed in 1922, the St. Paul Street West CN Rail Bridge has undergone extensive inspection and evaluation that has identified the structure for immediate replacement. The replacement will address the aging infrastructure and improve the vertical alignment of the roadway and the retaining walls on all bridge approaches.

Niagara Region is leading the project because of its close relation to the St. Catharines Train Station redevelopment to a multi-modal transit hub. Improvements to access the transit station via Great Western Street will be addressed.

In partnership with the City of St. Catharines, Ridley Road will also be reconstructed under this construction project.

Project update
Niagara Region has been observing the bridge's condition since load restrictions and lane closures were put in place in December 2022 due to the bridge's condition at that time.

Niagara Region and Canadian National Railway are closing the bridge due to the continuing deterioration of the structure. It would pose a significant risk to the health and safety of the public if it were to stay open.

The bridge is closing to all vehicles before the winter weather because it can no longer safely handle the traffic and

Contact
David Lampman, C.E.T.
Manager, Capital Projects, Transportation Engineering
Niagara Region
905-980-6000 ext. 3644
[Email: David.Lampman](mailto:David.Lampman@niagararegion.ca)

Public engagement
A public information open house is planned for September 2024 before construction starts.

Traffic Information
Westbound detour:
• St. Paul Street West • Dalhousie Street • North Street (Don't know)

JUNE 2024 - COMPLETED
Issue tender for the GO Station precinct development project

JULY 2024 - COMPLETED
Close tender for the GO Station precinct development project

AUGUST 2024 - COMPLETED
Demolition of properties at 96 St. Paul St. and 179 St. Paul Cres.

AUGUST 2024
Council approval to award construction contract

OCTOBER 2024
Start construction for the GO Station precinct development project